

第9章 机械加工工艺规程

9.1 工艺过程与工艺规程

9.1.1 概述

9.1.2 机械加工工艺过程的组成



图9.1.1 齿轮轴



图9.1.2 铣端面打中心孔工序

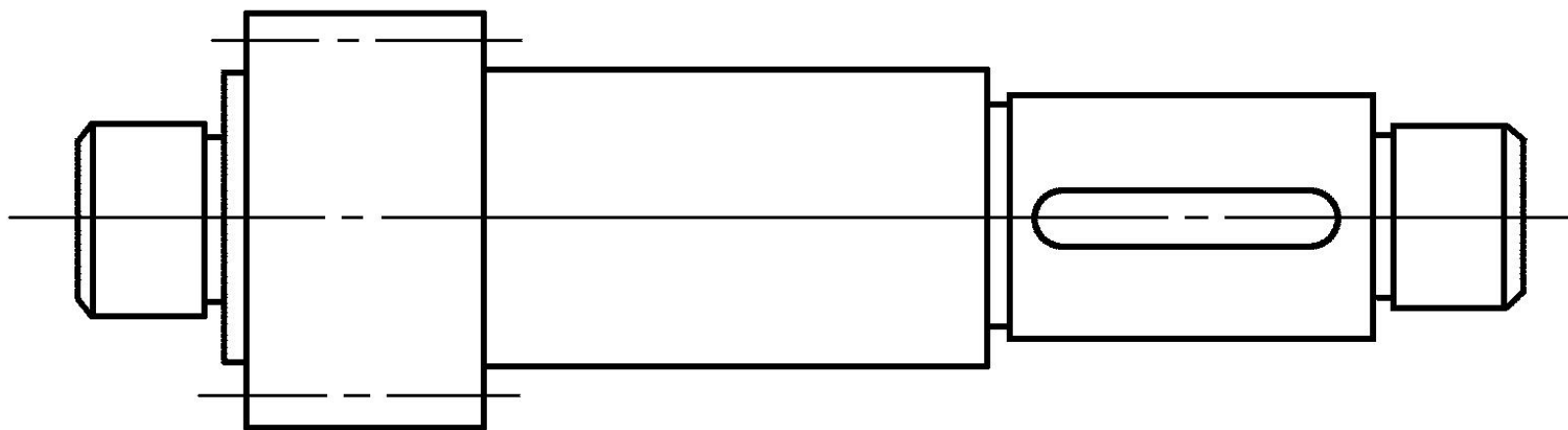

图9.1.3 盘类零件

9.2 典型零件机械加工工艺过程卡

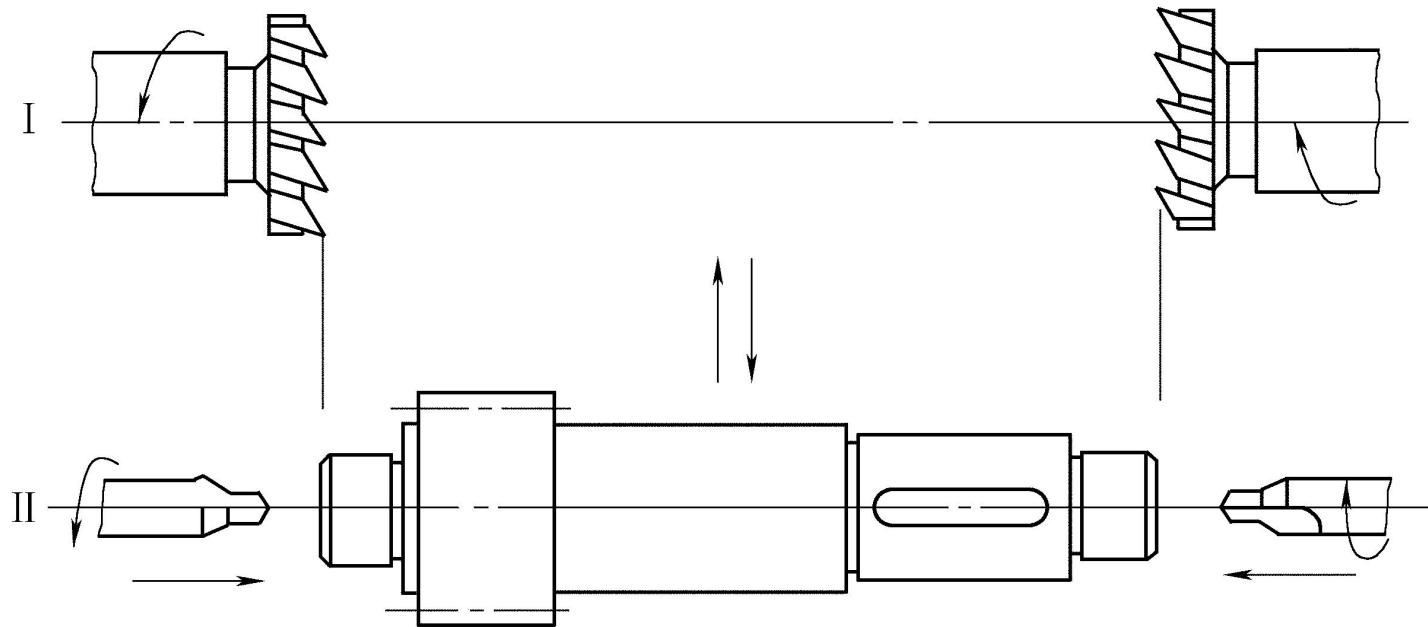
9.2.1 轴类零件加工

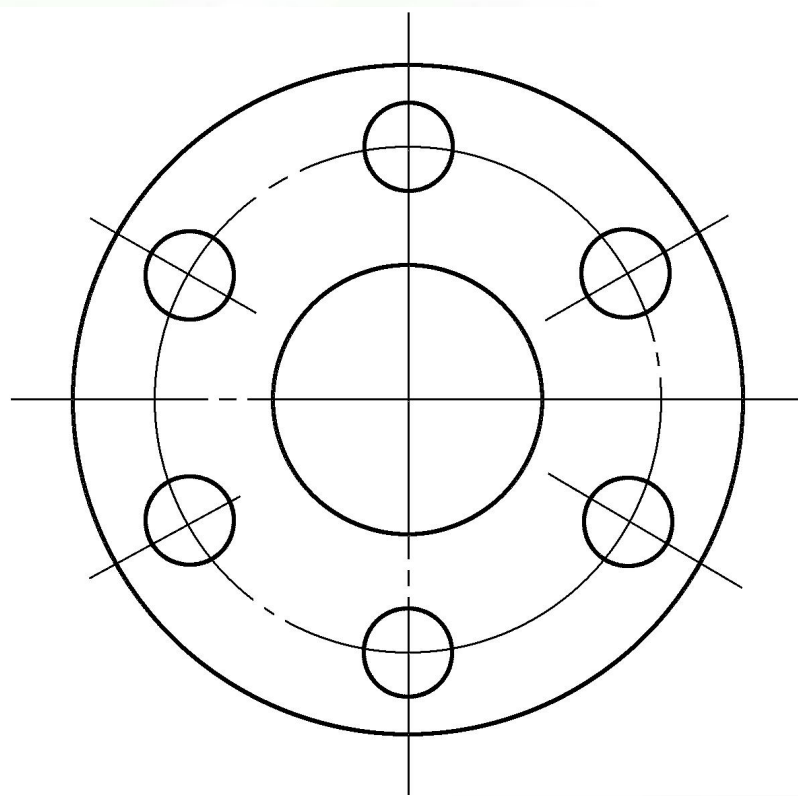

图9.2.1 轴

9.2.2 套类零件加工

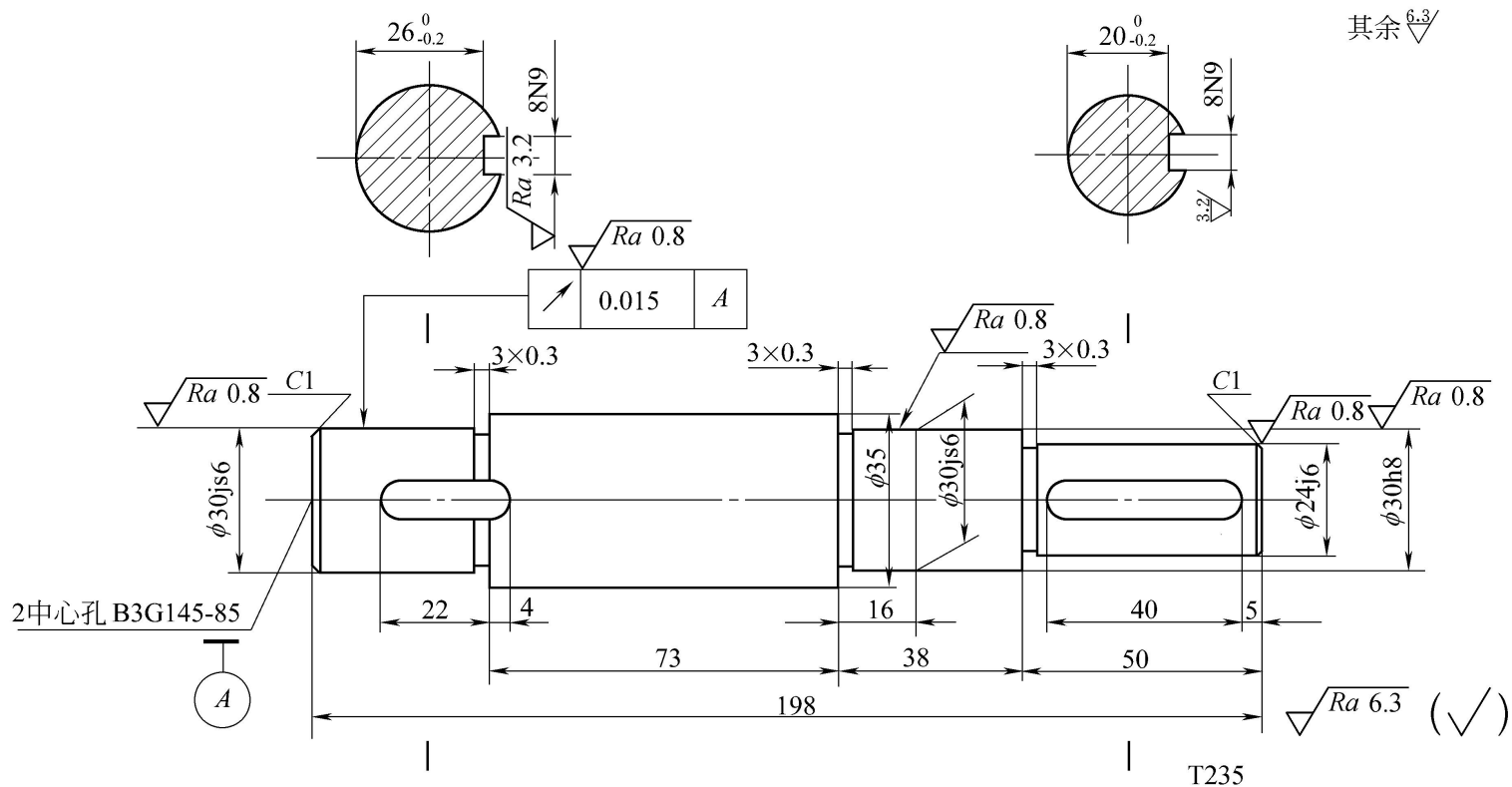

图9.2.2 套筒齿轮

9.2.3 箱类零件加工

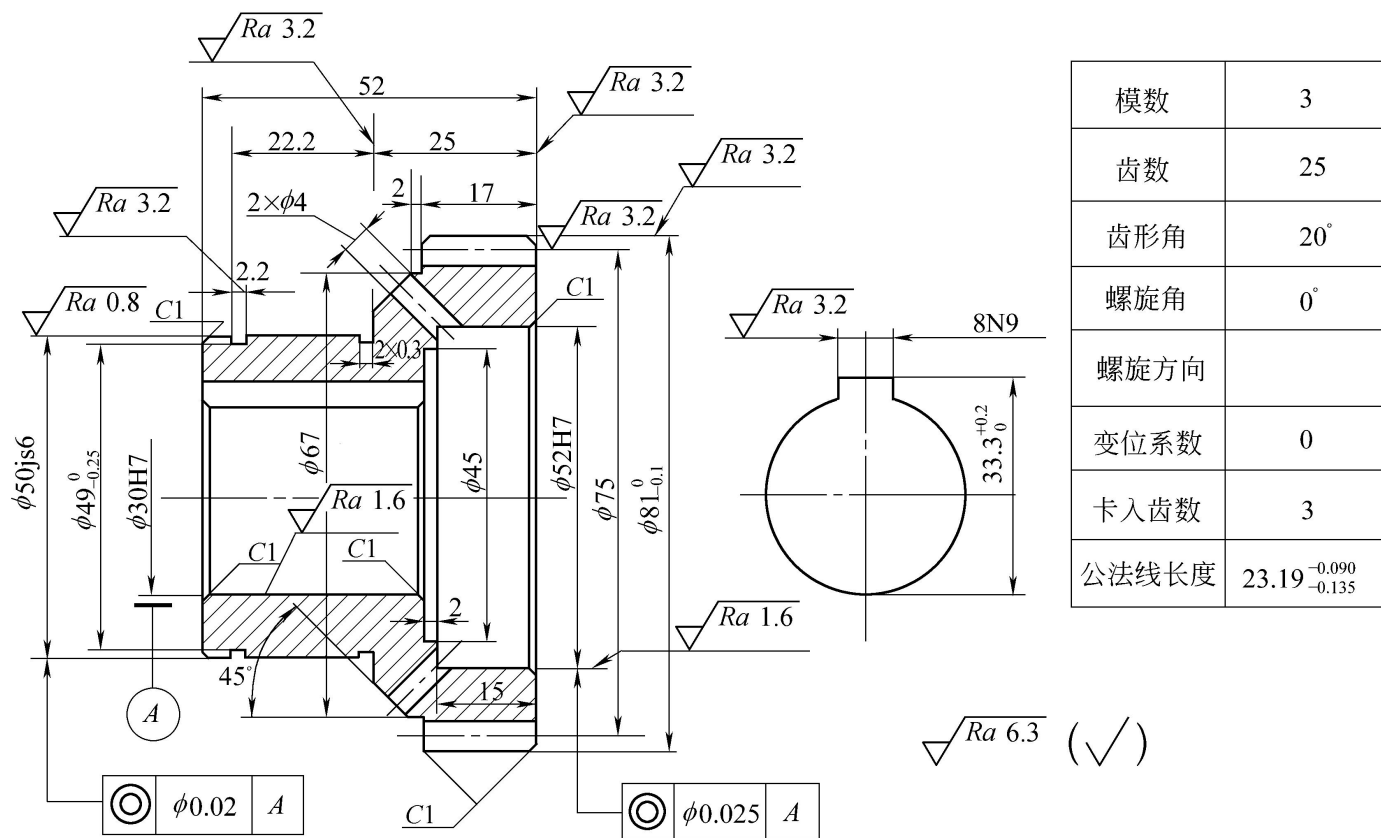
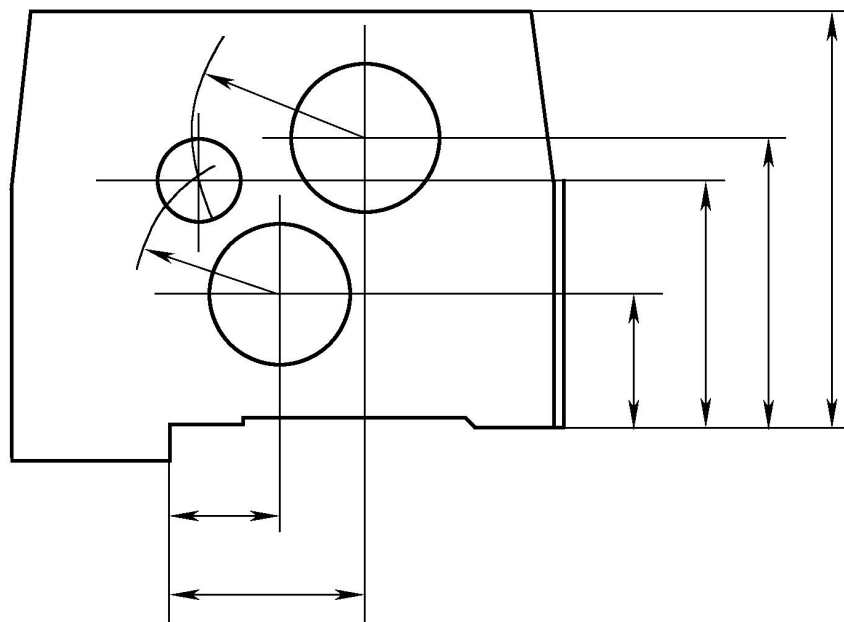

图9.2.3 车床床头箱